

MAIN VALVE OPTIONS

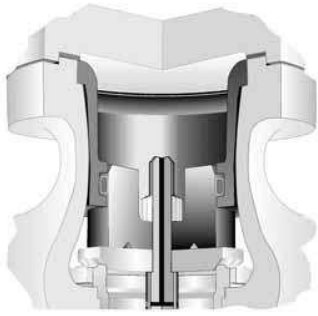

BALANCED CONSTRUCTION

There are installations where it is desirable to not have the inlet pressure forcing down on the Main Valve Disc. In these instances, the E Main Valve should be internally balanced. The balance parts allow the downstream pressure to rest on top of the disc, thus allowing for finer adjustments in the Main Valve travel and a smoother operating regulator. The balance cylinder is suitable for 550° F max temperatures.

SECOWELD

The greatest weakness in a High Pressure Valve is the threaded joint between the Seat Ring and the body. A slight leak developing at this point will gradually erode the Body metal, thus accentuating the leak and eventually ruining the body. Various impractical schemes, such as welding the Seat Ring into the Body, have been tried to overcome this weakness. The invention SECOWELD solves this problem and, at the same time, provides an easily renewable Seat Ring. In the SECOWELD Design, a SECO Metal Bushing is welded to and thus sealed in the Body and, in turn, is threaded to take the Main Seat Ring, which is also of SECO Metal. As SECO Metal resists wire drawing, if slight leakage should occur, no damage can be done to the body or to the threads of either SECO Metal piece.



EZ CONNECTIONS

Provides the performance of a flanged connection with the simplicity of a union connection. Unlike conventional unions, EZ Connections do not require matched sets or springing pipe to clear cone tolerances and do not leak after just a few disassembly/reassembly cycles. Uniform end to end dimensions simplify rough-in schematics. Available on 1/2" through 2" threaded main valves in NPT, socketweld and threaded by socketweld connections.

Consult Factory for pricing and availability.

CONDENSATION CHAMBER

A Condensation Chamber is standard on the Type E5 Main Valve. A Condensation Chamber is standard on the Type E Main Valve when steam temperatures exceed 600°F. Any Main Valve discharging steam into a vacuum should include a Condensation Chamber.

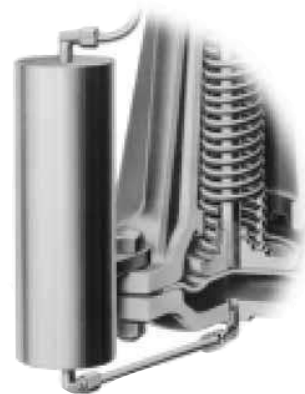

MAIN VALVE OPTIONS

LOW DIFFERENTIAL PRESSURE (LP) MAIN SPRING

The E Series Main Valves provide superior regulation in a broad range of applications by utilizing a specialized Main Spring. When differential pressures between 10-50 psi are desired, E Main Valves should be equipped with the optional LP Main Spring. The LP Main Spring alone will achieve differential pressures to 15 psi. In order to attain differential pressures to 10 psi, optional 5B Open Elbow and 1/16" 4A Bleedport are required.

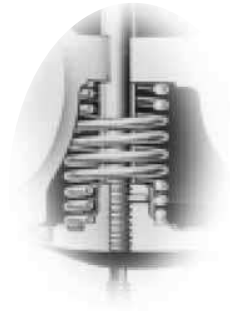

COMPOSITION DISC

In a Single Seat Main Valve, the Integral (all-metal) Disc is interchangeable with the Composition Disc Assembly. The Composition Disc is recommended for service on air, gas and water where absolutely tight shutoff is required and is available on Full and Normal seats and Parabolic valve plugs. The Composition Disc is suitable for pressures to 200 psi and temperatures to 200°F.

PARABOLIC DISC

In order to meet special flow requirements, any Spence Main Valve can be equipped with a Parabolic or other specially shaped Disc. Due to the fact that the Spence Main Valve is operated by a large, balanced Diaphragm and is nearly frictionless in operation, special Discs are not required on normal installations.

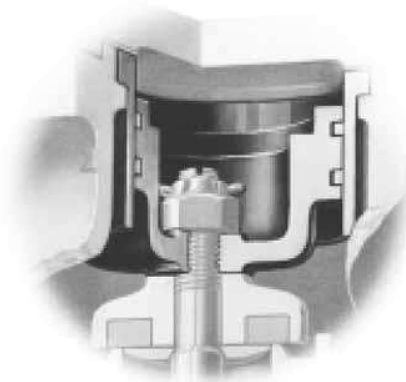
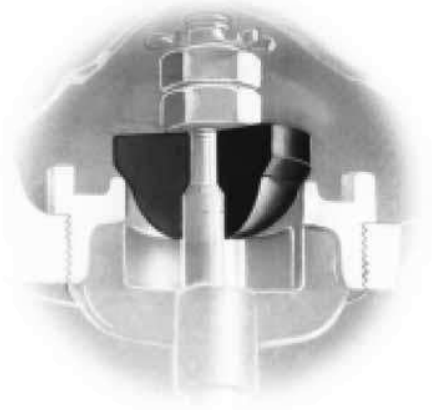

DASHPOT

In order to prevent water hammer, Dashpots are required in all single seat, normally closed Main Valves used on liquid service, except Type C34. Dashpots are neither necessary nor desirable on steam, air or gas service and are not required in double seat valves or in normally open single seat valves. Illustration shows Dashpot and Composition Disc for initial pressures of 200 psig and less. For initial pressures greater than 200 psig, standard metal to metal seat and disc are used.